



LA+



LAL+



LAH

PRODUCT DATA SHEET

DROP IN ANCHORS

SINGLE ANCHOR USE FOR NON-CRACKED CONCRETE



LA+, LAL+, LAH DROP IN ANCHORS

ETA-approved drop in anchors ideal for suspension systems

Internal thread for metric bolts and rods

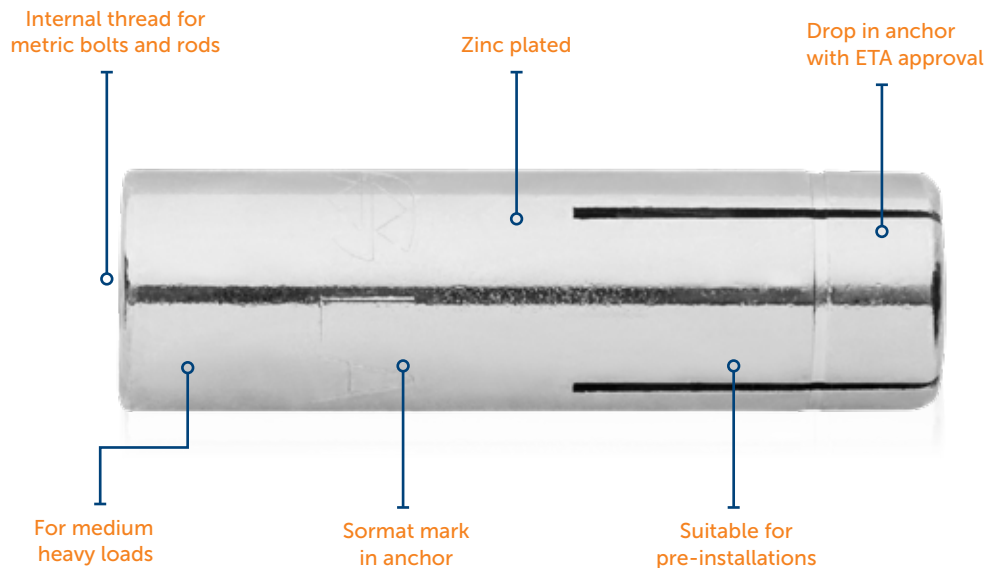

DROP IN ANCHORS LA, LA+, LAL+ AND LAH

Description

- Drop in anchors for pre-installations with an installation tool
- Internal thread for metric bolts and rods
- Suitable bolt length is 1-1,5 x the nominal size of the anchor + fixture thickness
- Suitable for medium heavy loads
- Displacement controlled expansion anchors
- Fixing screws or anchor rods
 - Steel grade categories 4.6, 5.6, 5.8 or 8.8 acc. EN ISO 898-1
 - Stainless steel A4-50, A4-70, A4-80



LA / LA+

Zinc plated drop in anchor without a collar



LAL+

Zinc plated drop in anchor with a collar



LAH

Stainless steel drop in anchor without a collar

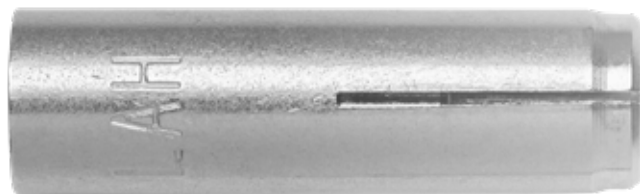

Base materials

Approved for



Non-cracked
concrete



Cracked
concrete
(See PDS of
multiple use)

Also suitable for



Solid
clay brick







Natural
stone



Hollow
concrete slab
(LAL+)

APPROVALS / CERTIFICATIONS / APPLICATIONS

Description of document		Authority/ Laboratory	ID	Additional info
European Technical Approval		Deutsches Institut für Bautechnik	ETA-13/0442	ETAG 001-1
Sormat Trustfix anchor calculation software		Sormat Oy / S&P Software Consulting		TrustFIX anchor calculation
Drop in anchors CAD-blocks for AutoCAD		Sormat Oy		Blocks installation instructions for AutoCAD
Drop in anchor components for TEKLA Structures		Sormat Oy		Tekla structures components + instructions video
YouTube installation videos		Sormat Oy		Drop in anchor presentation video
ProdLib		ProdLib Oy	prodlib.com/library/sormat	CAD block library

STATIC AND QUASI-STATIC LOADS FOR LA, LA+, LAL+

The data of these tables is based on:

- ETA-13/0442
- Non-cracked concrete C20/25, $f_{ck,cube} = 25 \text{ N/mm}^2$
- Installation has been done correctly (see page 8)
- No influence of edge- and spacing distances (see page 11)
- Respect of minimum base material thickness (see page 11)
- Load values are based on screw or rod with steel grade 4.6

Characteristic resistances

Anchor size	LA+ / LAL+					LA
	M6 x 25	M8 x 30	M10 x 40	M12 x 50	M16 x 65	M20 x 80
Approval	-	OPT 7	OPT 7	OPT 7	OPT 7	-
Effective anchorage depth h_{ef} [mm]	25	30	40	50	65	80
Non-cracked concrete						
Tensile N_{Rk} [kN]	5,8	7,5	12,0	16,0	26,5	36,1
Shear V_{Rk} [kN]	4,0*	7,3*	9,5*	15,4*	25,7*	49,0*

* Failure mode = STEEL

Design resistances

Anchor size	LA+ / LAL+					LA
	M6 x 25	M8 x 30	M10 x 40	M12 x 50	M16 x 65	M20 x 80
Approval	-	OPT 7	OPT 7	OPT 7	OPT 7	-
Effective anchorage depth h_{ef} [mm]	25	30	40	50	65	80
Non-cracked concrete						
Tensile N_{Rd} [kN]	2,7	5,0	6,7	8,8	14,7	16,7
Shear V_{Rd} [kN]	2,4*	4,3*	6,3*	10,2*	17,1*	29,4*

* Failure mode = STEEL

Recommended loads

Anchor size	LA+ / LAL+					LA
	M6 x 25	M8 x 30	M10 x 40	M12 x 50	M16 x 65	M20 x 80
Approval	-	OPT 7	OPT 7	OPT 7	OPT 7	-
Effective anchorage depth h_{ef} [mm]	25	30	40	50	65	80
Non-cracked concrete						
Tensile N_{rec} [kN]	1,9	3,6	4,8	6,3	10,5	11,9
Shear V_{rec} [kN]	1,7*	3,1*	4,5*	7,3*	12,2*	21,0*

* Failure mode = STEEL

The partial safety factor for action is $\gamma = 1.4$.

STATIC AND QUASI-STATIC LOADS FOR SINGLE ANCHOR

LAH

The data of these tables is based on:

- Non-cracked concrete C20/25, $f_{ck,cube} = 25 \text{ N/mm}^2$
- Installation has been done correctly (see page 8)
- No influence of edge- and spacing distances (see page 11)
- Respect of minimum base material thickness (see page 11)
- Load values are based on screw or rod with steel strength A4-50

Characteristic resistances

Anchor size	LAH					
	M6 x 25	M8 x 30	M10 x 40	M12 x 50	M16 x 65	M20 x 80
Approval	-	-	-	-	-	-
Effective anchorage depth h_{ef} [mm]	25	30	40	50	65	80
Non-cracked concrete						
Tensile N_{Rk} [kN]	4,9	8,1	10,3	17,4	25,8	35,2
Shear V_{Rk} [kN]	5,0*	9,2*	14,5*	21,1*	39,3*	61,3*

* Failure mode = STEEL

Design resistances

Anchor size	LAH					
	M6 x 25	M8 x 30	M10 x 40	M12 x 50	M16 x 65	M20 x 80
Approval	-	-	-	-	-	-
Effective anchorage depth h_{ef} [mm]	25	30	40	50	65	80
Non-cracked concrete						
Tensile N_{Rd} [kN]	2,3	3,8	4,9	8,3	12,3	16,8
Shear V_{Rd} [kN]	2,1*	3,9*	6,1*	8,9*	16,5*	25,8*

* Failure mode = STEEL

Recommended loads

Anchor size	LAH					
	M6 x 25	M8 x 30	M10 x 40	M12 x 50	M16 x 65	M20 x 80
Approval	-	-	-	-	-	-
Effective anchorage depth h_{ef} [mm]	25	30	40	50	65	80
Non-cracked concrete						
Tensile N_{rec} [kN]	1,7	2,7	3,5	5,9	8,8	12,0
Shear V_{rec} [kN]	1,5*	2,8*	4,4*	6,3*	11,8*	18,4*

* Failure mode = STEEL

The partial safety factor for action is $\gamma = 1.4$.

MATERIALS AND DIMENSIONS

Material quality and coating

Anchor

LA / LA+ / LAL+	Cold formed steel, Zinc electroplated min. 5 µm
LAH	Stainless steel A4

Mechanical properties

Specification				M6	M8	M10	M12	M16	M20	
Characteristic bending resistance	$M_{Rk,s}^0$	Screw/ Rod	4.6	[Nm]	6,1	15,0	29,9	52,4	132,8	259,6
			A4-50		7,6	18,7	37,4	65,5	166,5	324,5
Design bending resistance	$M_{Rd,s}$	Screw/ Rod	4.6	[Nm]	3,7	9,0	17,9	31,4	79,5	155,8
			A4-50		3,2	7,9	15,7	27,5	70,0	136,3
Recommended bending resistance	M_{rec}	Screw/ Rod	4.6	[Nm]	2,6	6,4	12,8	22,5	56,8	111,3
			A4-50		2,3	5,6	11,2	19,7	50,0	97,4

INSTALLATION

Installation data and anchor dimensions

Parameters and anchors sizes			M6 x 25	M8 x 30	M10 x 40	M12 x 50	M16 x 65	M20 x 80
Anchor outer diameter	d	[mm]	8	10	12	15	20	25
Drill hole diameter	d ₀	[mm]	8	10	12	15	20	25
Anchorage depth	h_{ef} / h_{nom}	[mm]	25	30	40	50	65	80
Depth of drilled hole to deepest point	$h_1 \geq$	[mm]	27	32	43	54	70	85
Diameter of the drill bit at the upper tolerance limit	$d_{cut,max} \leq$	[mm]	8,45	10,45	12,50	16,50	20,55	25,55
Diameter of clearance hole in the fixture	$d_f \leq$	[mm]	7	9	12	14	18	22
Max installation torque moment	T _{inst}	[Nm]	4	8	15	35	60	100
Maximum screwing depth LA/LA+/LAL+	L _{max}	[mm]	10	13	17	21	27	37
Maximum screwing depth LAH	L _{max}	[mm]	11	13	18	24	27	36
Minimum screwing depth	L _{min}	[mm]	6	8	10	12	16	20

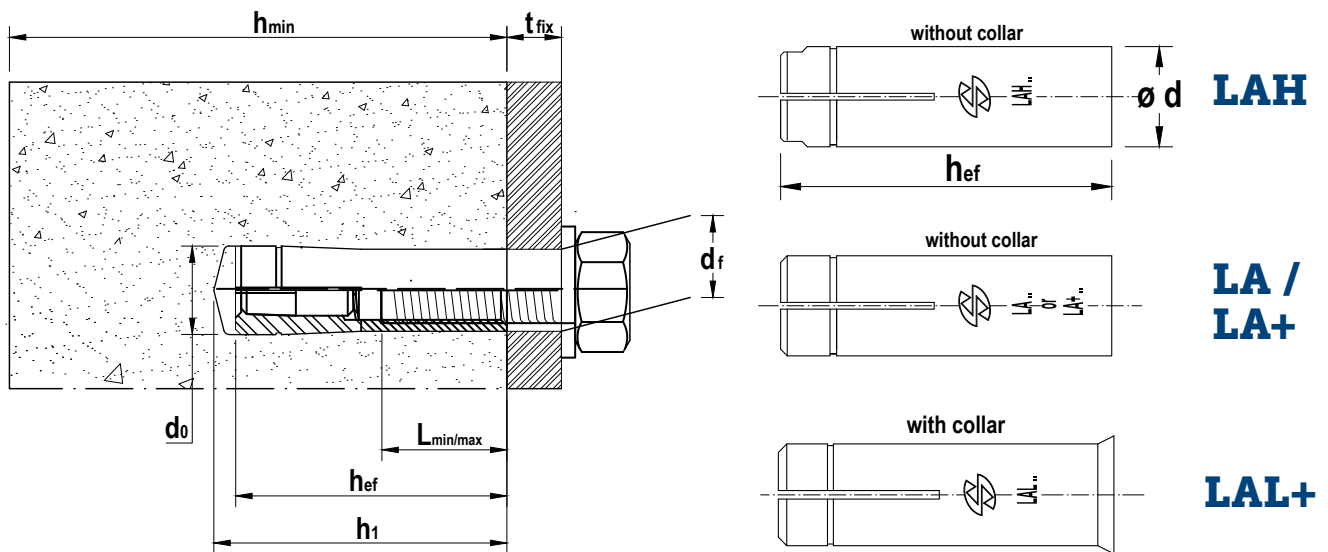

SETTING INSTRUCTIONS

Installation equipment

Specification	M6 x 25	M8 x 30	M10 x 40	M12 x 50	M16 x 65	M20 x 80
Drill bit	SDS+ 2-CUT or 4-CUT					
	8	10	12	15	20	25
Rotary hammer	750...1200 r.p.m / 1.8 ...3.3 J					
						360...550 r.p.m / 4,9 ...11,5 J
Additional tools	Air pump/compressor, LT+ or LT+ PRO Punch tool, hammer, torque wrench					

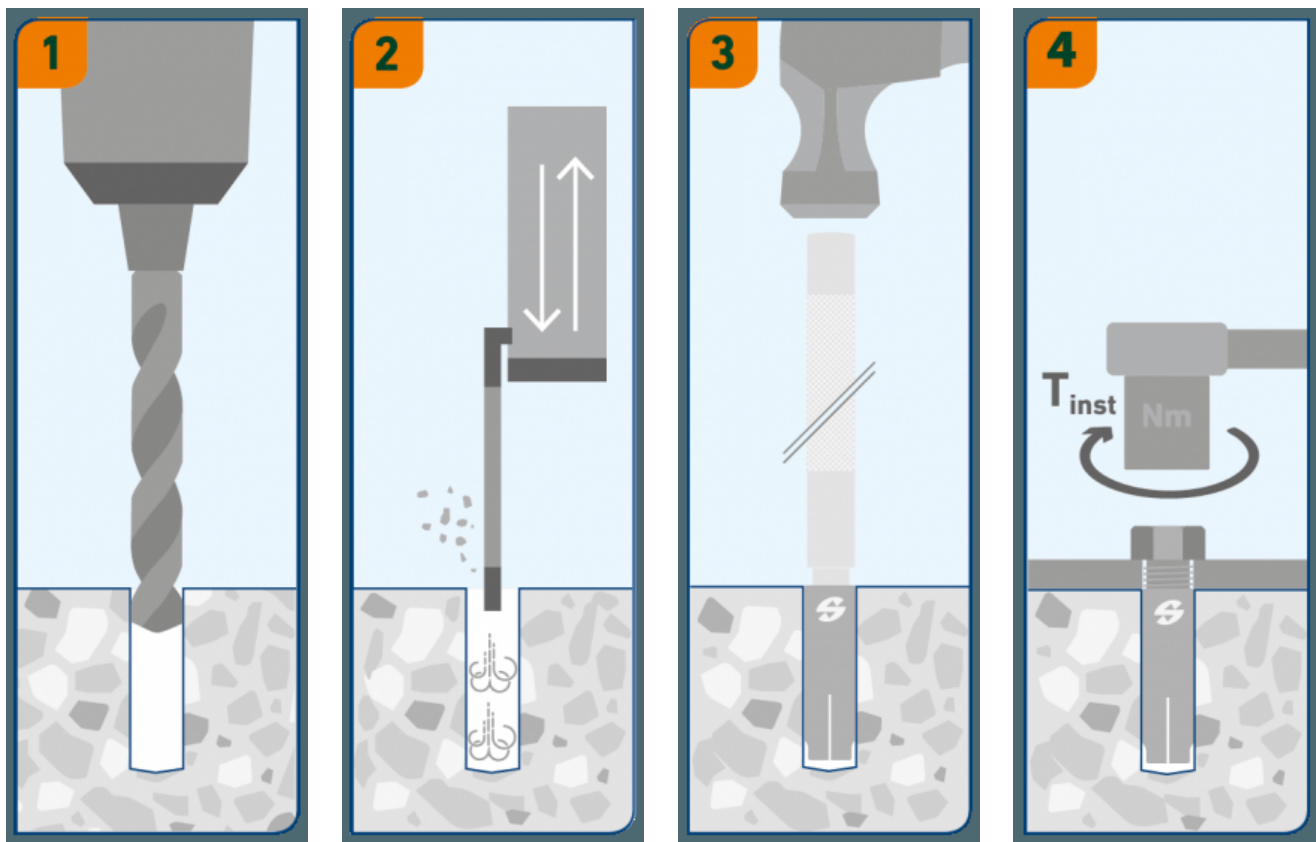

LA+, LAL+, LAH DROP IN ANCHORS

INSTALLATION

Setting tools

Anchor		M6 x 25	M8 x 30	M10 x 40	M12 x 50	M16 x 65	M20 x 80
Hardened carbon steel	Tool	LT+ 6	LT+ 8	LT+ 10	LT+ 12	LT+ 16	LT 20
		LT+ 6 PRO	LT+ 8 PRO	LT+ 10 PRO	LT+ 12 PRO	LT+ 16 PRO	-
D1	[mm]	5	6,6	8,3	10,2	13,9	16,5
D2	[mm]	7,5	9,5	12	14	19	23
D3	[mm]	12	12	12	19	19	25
L1	[mm]	15	17,5	23,5	29	39	51
L2	[mm]	35	40	0	40	0	20
L3	[mm]	220	220	220	220	240	210

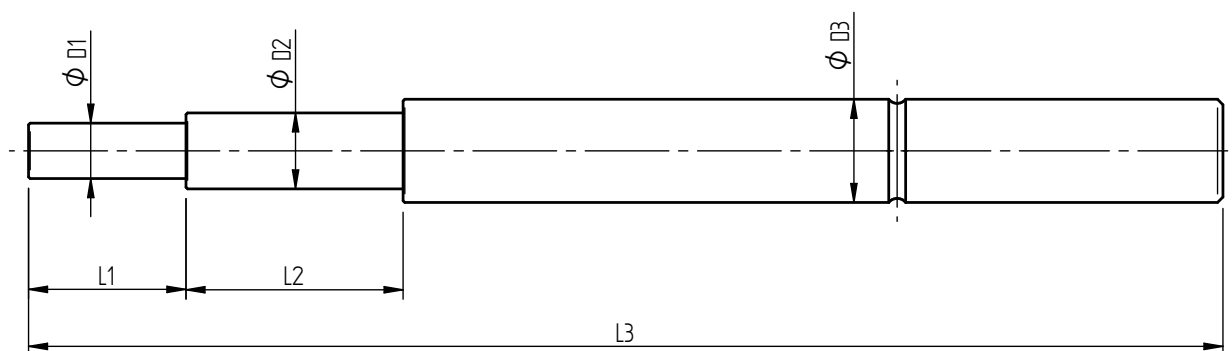

LT+ PRO



LT+



Minimum thickness of concrete member, spacing and edge distance

LA/LA+/LAL+			M6 x 25	M8 x 30	M10 x 40	M12 x 50	M16 x 65	M20 x 80
Non-cracked concrete								
Approval			-	OPT 7	OPT 7	OPT 7	OPT 7	-
Anchorage depth	$h_{ef} = h_{nom}$	[mm]	25	30	40	50	65	80
Minimum thickness of base material	h_{min}	[mm]	100	100	100	120	160	120
Minimum spacing	s_{min}	[mm]	70	105	105	125	180	240
Minimum edge distance	c_{min}	[mm]	105	105	140	175	230	280
Critical spacing for splitting failure and concrete cone failure (in case characteristic loading affects)	$s_{cr, sp}$	[mm]	NA	210	280	350	460	NA
	$s_{cr, N}$	[mm]	80	90	120	150	195	240
Critical edge distance for splitting failure and concrete cone failure (in case characteristic loading affects)	$c_{cr, sp}$	[mm]	NA	105	140	175	230	NA
	$c_{cr, N}$	[mm]	40	45	60	75	98	120

LAH			M6 x 25	M8 x 30	M10 x 40	M12 x 50	M16 x 65	M20 x 80
Non-cracked concrete								
Approval			-	-	-	-	-	-
Anchorage depth	$h_{ef} = h_{nom}$	[mm]	25	30	40	50	65	80
Minimum thickness of base material	h_{min}	[mm]	100	100	100	120	160	120
Minimum spacing	s_{min}	[mm]	70	130	105	125	180	240
Minimum edge distance	c_{min}	[mm]	105	105	140	175	230	280
Critical spacing for splitting failure and concrete cone failure (in case characteristic loading affects)	$s_{cr, sp}$	[mm]	NA	210	280	350	460	NA
	$s_{cr, N}$	[mm]	80	90	120	150	195	240
Critical edge distance for splitting failure and concrete cone failure (in case characteristic loading affects)	$c_{cr, sp}$	[mm]	NA	105	140	175	230	NA
	$c_{cr, N}$	[mm]	40	45	60	75	98	120

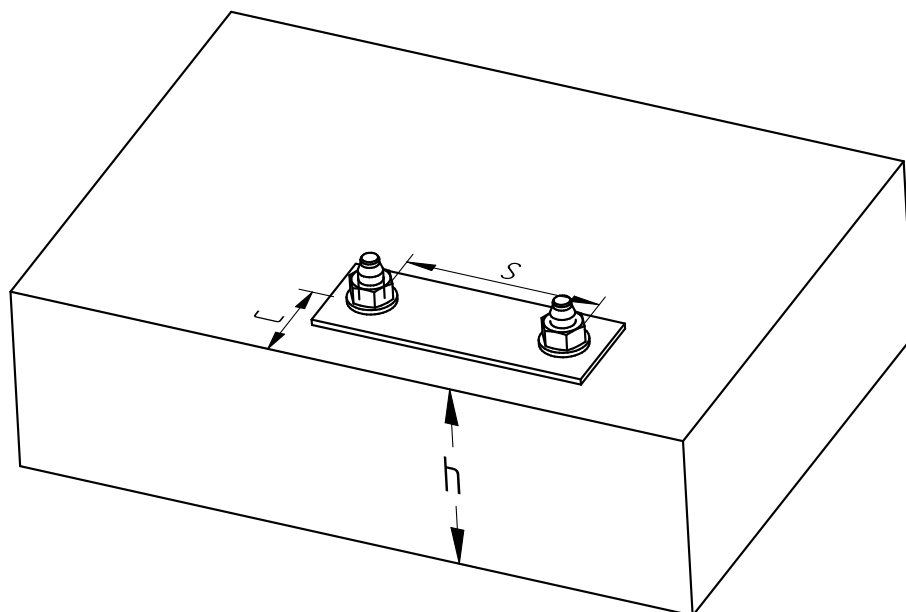

Delivery program



Size	Length	ETA		Zinc	Zinc	A4
M6 x 25	25	-	PART 6 OPT 7	LA+ 6	LAL+ 6	LAH 6 *
M8 x 30	30			LA+ 8	LAL+ 8	LAH 8 *
M10 x 40	40			LA+ 10	LAL+ 10	LAH 10 *
M12 x 50	50			LA+ 12	LAL+ 12	LAH 12 *
M16 x 65	65			LA+ 16	LAL+ 16	LAH 16 *
M20 x 80	80	-		LA 20 *		LAH 20 *

* No ETA

LT+ PRO



LT+

